

ATTENTION

There is a potential risk of serious injury or death associated with virtually every product regardless of its type or intended use. Stander, Inc., has worked tirelessly to minimize all risks associated with its mobility aids, yet given the types of products, users, and a myriad of things outside of our control, we cannot eliminate every conceivable risk. Accordingly, a consumer must use common sense when utilizing our products and consider the user's overall physical and mental health.

Read all of the materials that accompany this product before it is installed or used.

LIMITED WARRANTY

Stander, Inc. warrants to the original purchaser that this product will be free from defects in material and/or workmanship for 1 year from the date of purchase. During the warranty period we will correct any defects in material or workmanship at no charge. All shipping cost must be paid by the original purchaser. Any replacement parts will be new and are warranted for the remainder of the original warranty or thirty (30) days from the date of shipment, whichever is longer. The original purchaser must notify Stander, Inc. during the warranty period in writing of the defect in workmanship or material. This warranty is not transferable and covers only normal use. Stander will not refund or pay for any shipping charges. The warranty does NOT cover: (1) Damage during shipment other than original shipment to retailer; (2) Damage caused by unauthorized attachments, alterations, or modifications; (3) Damage caused by the use of the product for purposes other than those for which the product was designed or intended; and (4) Damage caused by any other abuse, misuse, mishandling or misapplication.

Under no circumstances shall Stander, Inc. be liable for any special, incidental, or consequential damages based upon breach of this limited warranty, breach of contract, or strict liability.

THERE ARE NO WARRANTIES WHICH EXTEND BEYOND THOSE INDICATED HEREIN. ALL OTHER WARRANTIES, EXPRESS OR IMPLIED (INCLUDING ALL IMPLIED WARRANTIES OF MERCHANTABILITY OR FITNESS FOR A PARTICULAR PURPOSE), ARE HEREBY DISCLAIMED.

Some states do not allow limitations on how long an implied warranty lasts, so the above limitation may not apply to you. This warranty gives you specific legal right, and you may also have other rights which vary from state to state. To obtain service under this warranty, you can reach Stander, Inc. at (800) 506-9901 or (435) 755-0453.

WARNINGS

1) INSTALLATION:

- a) Do not use or install this product unless you read and understand these warnings and assembly instructions to ensure the product is properly installed and used. If installer/user(s) are installing this product in a nursing home, assisted living center, or a similar facility, follow these and the facilities installation policies. If you have any questions regarding the installation, use, associated risks, or anything at all regarding this product call Stander Inc. at (800) 506-9901 or (435) 755-0453.
- b) Improper installation of this product significantly increases the risk of falls. These accessory products attach to the Stander Signature Life pole (Model 7620 or 7621) that secures between the floor and ceiling. Since there are many different types of floor and ceiling conditions, it is up to the installer and/or user of this product to determine if the product can be safely installed.
- c) **IMPORTANT:** The pole can become loose (not properly secured between floor and ceiling) because of the myriad of conditions. It is the installer and/or users responsibility to periodically check and secure the pole between the floor and ceiling with the included wrench. Do NOT discard included wrench.
- d) Do NOT install the pole product with accessories on suspended ceilings, or any other type of ceiling that would not allow the product to be properly secured between a floor and ceiling. The pole must be installed perpendicular to the floor and ceiling. All protective rubber pads should engage the ceiling and floor with an equally distributed force.
- e) Do NOT install pole product on ceiling heights less than 7 feet or greater than 10 feet.
- f) Do NOT install the pole product on a platform or any other surface that is raised off the floor. If you have questions, it is the installer/user(s) responsibility to call Stander Inc. at (800) 506-9901 or (435) 755-0453. Do not install this product if you are not sure the product can be properly secured.
- g) Floor conditions also affect the ability to install the product securely. Do NOT install the product on rugs or any other moveable objects. Do NOT install the product on floor conditions that would allow the base of the pole to slide or slip. If the base or the top of the pole moves after installation, the product is not safe to use. Screws are included to anchor the base and top of the pole (Items 1 and 5 in these instructions).
- h) This pole product with attached accessories are not intended to be placed inside a bathtub or inside a shower.
- i) **IMPORTANT:** If installing the pole product next to a bed, couch, toilet, or any other object, Stander Inc. recommends NOT installing product closer than the user(s) ability to safely walk around the pole with accessories attached or there may be a possibility of becoming entrapped between the pole and the side of any object adjacent to the pole and/or accessories. Entrapment is a condition where an individual may become lodged between objects. The handles on the pole must be considered when placing the pole next an adjacent object. In other words, the handle can be positioned 360 degrees around the pole. The user(s) must be able to safely walk around the pole in every handle position. It is the user(s) responsibility to ensure there is no possible way to become entrapped between the pole and handle and the side of any object adjacent to the pole. Since there are a myriad of user conditions, installer/user(s) should determine if the pole should be installed farther away from the side of a bed. If you have questions, it is the installer/user(s) responsibility to call Stander Inc. at (800) 506-9901 or (435) 755-0453.

2) PHYSICAL AND MENTAL CONDITIONS:

- a) Individuals who have problems with physical limitations, paralysis, symptoms of dementia, Alzheimer's or memory loss, sleeping, incontinence, pain, uncontrolled body movement, getting out of bed and walk unsafely without assistance, frailty, weakness, confusion, restlessness, terminal restlessness, or are under the influence of medications, drugs or any substance that could impair their balance or judgment, or any other unforeseeable reasons that could affect the users physical and mental ability to safely use this product, are at a higher risk of entrapment. Since these conditions are subjective and Stander Inc. has no control who chooses to use this product, it is the installer/user(s) responsibility to consult a physician before using this product.
- b) This product is not intended to carry the full weight of an individual. This product is only intended to provide balance and support while sitting and standing.

3) EXTERNAL FACTORS:

- a) Children should not be allowed to hang on or play with the pole or this accessory product.
- b) Due to external unforeseeable factors, the pole and/or the accessory products may become loose. Periodically check and increase the tension between the floor and ceiling with the included wrench if the pole becomes loose. Also check the accessory to see if it is loose and tighten with the enclosed tools. Do NOT discard the included tools.
- c) Floor conditions can affect the stability of the pole such as floor irregularities, wet surfaces, or other conditions that would allow the base of the product to move with the accessory attached. Do NOT use product on floor surfaces that allow the base of the product to move (especially with the accessory attached).
- d) If product is removed and reinstalled, the pole and accessory needs to be reinstalled correctly as directed in these instructions. Keep instructions for future reference.

4) AGREEMENT BETWEEN INSTALLER/USER(S) AND STANDER INC.:

- a) If the installer/user(s) choose to use this product, it is understood between the installer/user(s) AND Stander Inc., that the installer/user(s) accept the risks associated with using this product. Since these conditions are subjective and Stander Inc. has no control over who chooses to use this product, the installer/user(s) agree to be liable for their decisions when using this product.

5) CONSUMER RIGHTS AND ARBITRATION AGREEMENT:

- a) This arbitration agreement (Agreement) affects your legal rights and remedies by providing that disputes between you and the manufacture of this product (Stander), must be resolved through binding arbitration, rather than in a court. Please read this agreement carefully as you accept the terms of this agreement by assembling and using this product. If you do not agree to the terms of this agreement, return the product to the location of purchase for a refund.
 - i) RESOLUTION OF CLAIMS OR DISPUTES. Any claim or dispute between you and Stander arising out of or relating in any way to the Product or this Agreement shall be resolved through final, binding arbitration. This arbitration obligation applies regardless of whether the claim or dispute involves a tort, fraud, misrepresentation, product liability, negligence, violation of a statute, or any other legal theory. Both you and Stander specifically acknowledge and agree that you waive your right to bring a lawsuit based on such claims or disputes and to have such lawsuit resolved by a judge or jury.
 - ii) LIMITATION OF LEGAL REMEDIES. All arbitrations under this Agreement shall be conducted only on an individual (and not a class-wide) basis and an arbitrator shall have no authority to award class-wide relief. You acknowledge and agree that this Agreement specifically prohibits you from commencing arbitration proceedings as a representative of others or joining in any arbitration proceedings brought by any other person. iii) ARBITRATION PROCEDURES.
 - (1) Before commencing any arbitration proceedings under this Agreement, you must first present the claim/dispute to Stander by calling (800) 506-9901 or (435) 755-0453, providing requested contact information and allowing Stander the opportunity to resolve it. If your claim or dispute is not resolved within sixty (60) days, you may commence arbitration proceedings in accordance with the terms of this Agreement.
 - (2) The arbitration of claim(s)/dispute(s) under this Agreement shall be pursuant to the American Arbitration Association's (AAA) United States Commercial Dispute Resolution Procedures and Supplementary Procedures for Consumer Related Disputes (see www.adr.org for their rules and procedures).
 - (3) The arbitration of any claim/dispute under this Agreement shall be in the State of Utah.
 - (4) All administrative expenses of arbitration proceedings under this Agreement shall be divided equally between you and the Company, except that: (a) if the claims/dispute subject to the arbitration proceedings is less than ten thousand dollars (US\$10,000), you will be responsible for no more than one hundred twenty-five dollars (US\$125) in administrative expenses; (b) if the claim/dispute subject to the arbitration proceedings is more than ten thousand dollars (US\$10,000) but less than seventy-five thousand dollars (US\$75,000), then you will be responsible for no more than three hundred seventy-five dollars (US\$375) in administrative expenses; and (c) if the claim/dispute subject to the arbitration proceedings is more than seventy-five thousand dollars (US\$75,000), then you will be responsible for administrative expenses in accordance with the Commercial Fee Schedule provided by the AAA. You acknowledge and agree that each party shall pay the fees and costs of its own counsel, experts and witnesses.
 - iv) CHOICE OF LAW & SEVERABILITY. This Agreement shall be governed by the United States Federal Arbitration Act and the laws of the state of Utah. If any provision of this Agreement is declared or found to be unlawful, unenforceable or void, such provision will be ineffective only to the extent that it is found unlawful, unenforceable or void and the remainder shall remain fully enforceable.

WARNING **ENTRAPMENT AND FALL HAZARD**

- Small gaps between this product and other stationary objects can entrap and kill.
- People with Alzheimer's disease or dementia, or those who are sedated, confused, or frail, are at increased risk of entrapment and falls.
- Always make sure the pole product is properly secured between the floor and ceiling when using accessories.
- Make sure the product has sufficient space to allow user(s) to walk between the pole/accessories and any other stationary object.
- Do NOT use or place near children's beds, bunk beds, water beds, or inflatable beds.
- Failure to comply with these conditions could put the user(s) at risk of entrapment or falling.



Assembly Instructions:

ITEM	QTY	DESCRIPTION
1	1	CEILING PIVOT ASSEMBLY
2	2	SMALL DIAMETER TUBE
3	2	LARGE DIAMETER TUBE
4	1	THREADED ADJUSTMENT ASSEMBLY
5	1	FLOOR BASE ASSEMBLY
6	2	HEIGHT ADJUSTMENT PINS
7	1	PROTECTIVE COVER
8	5	WOOD SCREWS
9	1	ALLEN WRENCH
10	1	ADJUSTMENT WRENCH

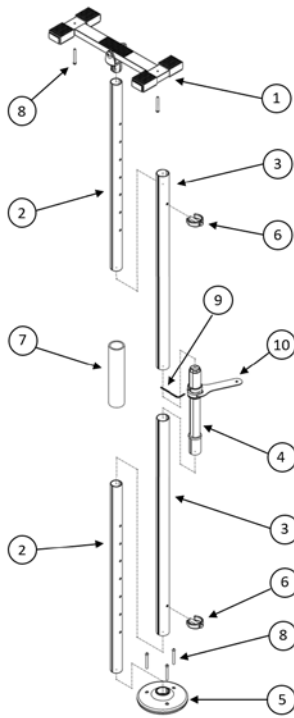

FIGURE 1

NOTE: This product (pole and/or accessories) are designed to be used with ceiling heights that range from 7 to 10-foot ceilings. For 10 to 12-foot ceiling heights, an Extension Tube can be purchased separately by calling Stander Incorporated at (800) 506-9901 or (435) 755-0453.

1. Take all parts out of the box and lay them on a flat surface near the place the product is to be installed as shown in Figure 1.
2. The THREADED HEIGHT ADJUSTMENT ASSEMBLY (# 4) must look like Figure 2 before starting. The maximum amount of threads should be exposed at the end of the assembly.

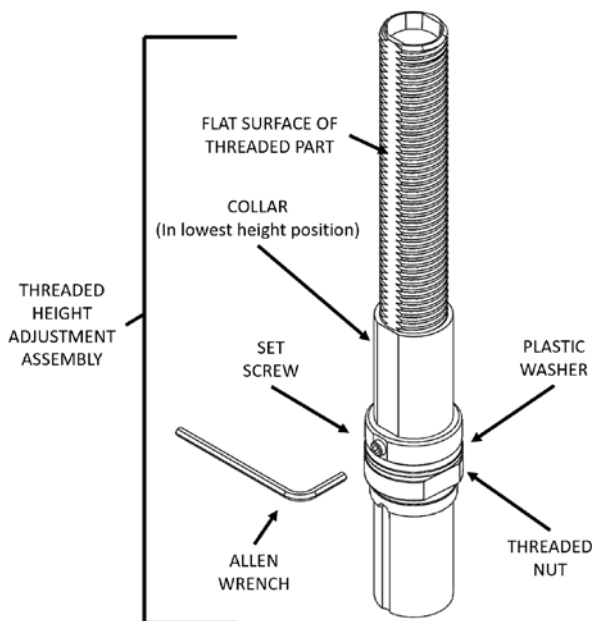

FIGURE 2

3. Insert the THREADED ADJUSTMENT ASSEMBLY shown in Figure 2 into the LARGE DIAMETER TUBES (# 3) as shown in Figure 3.

NOTE: The exposed threaded section should be oriented towards the ceiling.

The COLLAR (in Figure 2) has a SET SCREW that must be aligned with the flat surface of threaded part as shown in Figure 2.

LIGHTLY tighten the SET SCREW with the ALLEN WRENCH (#9) to prevent the collar from spinning.

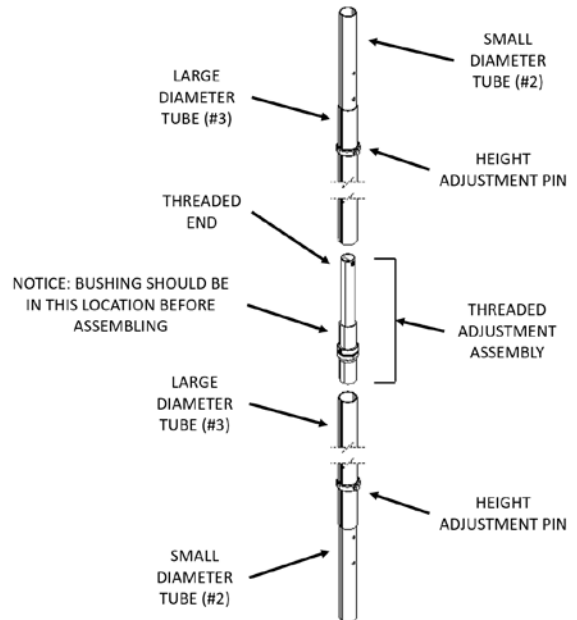

FIGURE 3

4. Determine the height of the ceiling where product will be installed.
5. Insert the SMALL DIAMETER TUBES (#2) into the LARGE DIAMETER TUBES (#3) as shown in Figure 4. Align the appropriate ceiling height hole in the SMALL DIAMETER TUBE with the hole in the LARGE DIAMETER TUBE (#3) and insert the HEIGHT ADJUSTMENT PINS (#6) through the aligned holes.

NOTE:

- a) The SMALL DIAMETER TUBES (# 2) can be inserted into the LARGE DIAMETER TUBES (# 3) in either direction since holes are equally spaced.
- b) Figure 4 identifies 7, 8, 9, and 10-foot ceiling height holes with arrows. The holes located in-between the arrows should be used for ceiling heights that are close to 7-1/2, 8-1/2, and 9-1/2 ceiling heights. Pole can be adjusted +/- 3 inches with the Threaded Adjustment Assembly (#4)

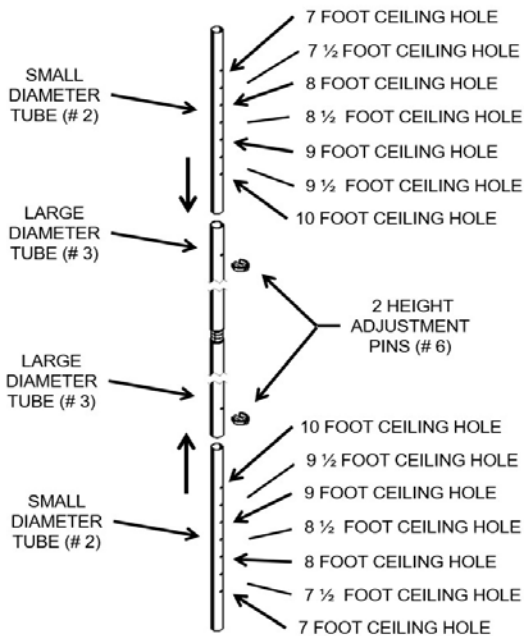

FIGURE 4

CAUTION: At this point, it would be advised to have 2 people involved with installing the product to avoid any potential harm to installers or damage to the floor.

Excessive movements or tilting of the product could cause the CEILING PIVOT ASSEMBLY (#1) to come off and potentially cause harm to the installers or damage to the floor.

6. Insert the CEILING PIVOT ASSEMBLY (#1) into the SMALL DIAMETER TUBE (#2) as shown in Figure 5.

Place the FLOOR BASE ASSEMBLY (#5) on the floor where the product is to be installed and then insert the other SMALL DIAMETER TUBE (#2) into the FLOOR BASE ASSEMBLY (#5) as shown in Figure 5.

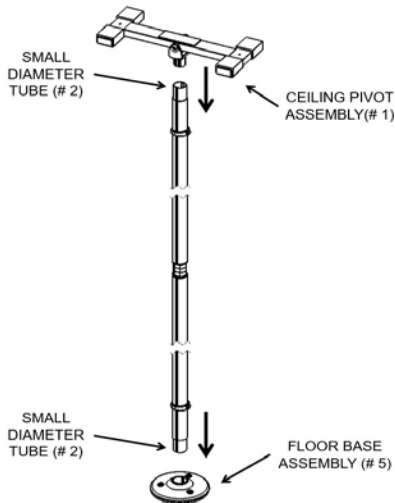

FIGURE 5

7. If the ceiling is sloped relative to the floor, remove the PIVOT ISOLATOR using a 6mm Allen wrench (not supplied) and 16mm wrench (not supplied) from the CEILING PIVOT ASSEMBLY, as shown in Figure 6a. If the ceiling is parallel to the floor, DO NOT remove PIVOT ISOLATOR.

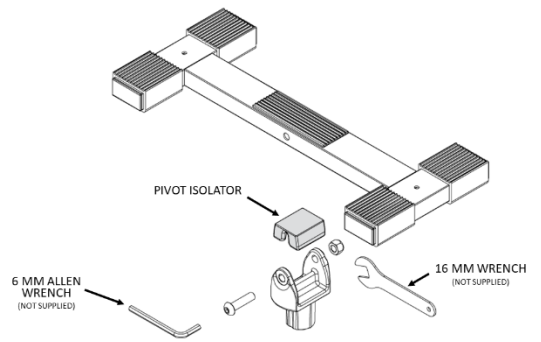

FIGURE 6a

If PIVOT ISOLATOR is removed, CEILING PIVOT ASSEMBLY (#1) will need to be secured to the Ceiling Wood Joist with included WOOD SCREWS (#9), as shown in Figure 6b.

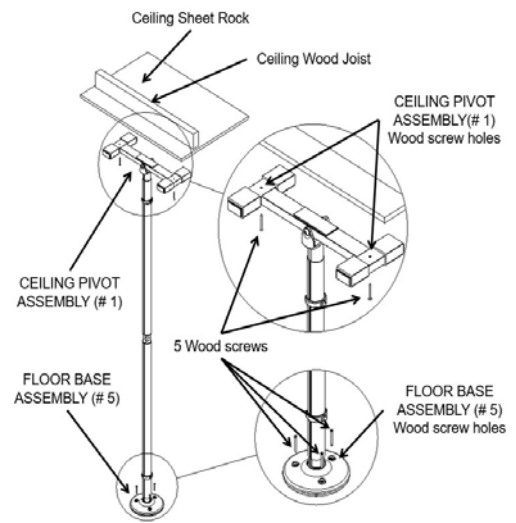

FIGURE 6b

NOTE: WOOD SCREWS (#9) are mandatory if PIVOT ISOLATOR is removed and optional if the ceiling is parallel to the floor and PIVOT ISOLATOR is not removed; however, if CEILING PIVOT ASSEMBLY (#1) and/or FLOOR BASE ASSEMBLY (#5) move after installation is complete, use WOOD SCREWS (#9) to -secure the product to the floor and ceiling as shown in Figure 6b.

8. Loosen the SET SCREW with the ALLEN WRENCH (#9).

Using the ADJUSTMENT WRENCH (#10), rotate the THREADED NUT on THREADED ADJUSTMENT ASSEMBLY (# 4) to allow the pole to expand between the floor and the ceiling. Make sure the pole is perpendicular to the floor in all directions and then tighten the THREADED NUT.

After the THREADED NUT has been tightened, use the ALLEN WRENCH (#9) to tighten the SET SCREW as shown in Figure 7.

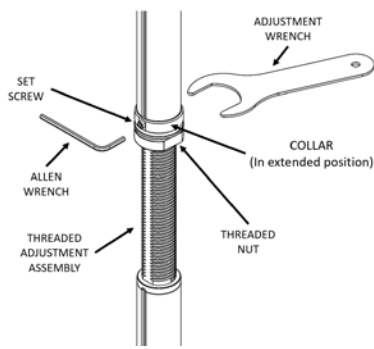

FIGURE 7

9. Secure PROTECTIVE COVER (#7) around exposed threaded area of THREADED ADJUSTMENT ASSEMBLY (#4) as shown in Figure 8.

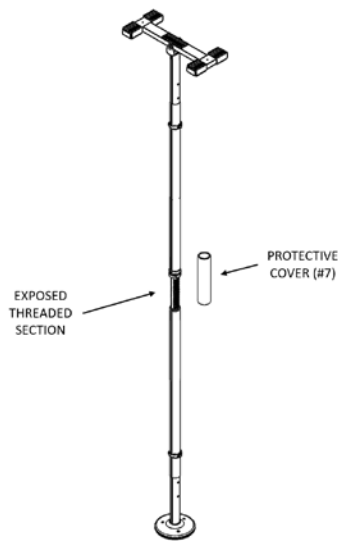

FIGURE 8

WARNINGS:

After the pole is secured between the floor and ceiling, check the length of exposed threaded area. Do NOT install if the total length of exposed threaded sections plus the THREADED NUT of the THREADED ADJUSTMENT ASSEMBLY (#4) is longer than 7 inches.

When the pole is installed properly there should be no movement between the TOP ASSEMBLY ITEM-1 and the ceiling and the FOOR BASE ASSEMBLY (#5) and the floor when in use. It is important to inspect the pole frequently to ensure the pole does not move.

Since there are many unforeseeable conditions (conditions where the pole may move or become loose), Stander Inc. has provided the installer/user(s) the ability to anchor the product to the floor and ceiling using the included WOOD SCREWS (#8). If the pole moves or becomes loose, install the WOOD SCREWS to secure the product.

When installing the WOOD SCREWS (# 8), it is important that the screws secure the CEILING PIVOT ASSEMBLY (#1) to the wood ceiling joists.

Tile floor conditions: If the FOOR BASE ASSEMBLY (#5) is to be mounted to a ceramic tile floor, holes must first be drilled through the tile only before using the WOOD SCREWS (#8). Place the WOOD SCREWS (#8) through

the Floor Base Assembly (# 5) holes and secure into the wood floor.

Linoleum or carpeted floors: If the FOOR BASE ASSEMBLY (#5) is to be mounted on either Linoleum or carpeted floors, place the WOOD SCREWS (#8) through the FOOR BASE ASSEMBLY (# 5) holes and secure directly into the wood floor as shown in Figure 6.

If the installer/user(s) have any questions or concerns, please call Stander Inc. at (800) 506-9901 or (435) 755-0453.